

Summary - CIC Interpolator

Name	cic_int
Worker Type	Application
Version	v1.5
Release Date	4/2019
Component Library	ocpi.assets.dsp_comps
Workers	cic_int.hdl
Tested Platforms	xsim, isim, modelsim, alst4, ml605, ZedBoard(PL), Matchstiq-Z1(PL)

Functionality

The CIC interpolator has N cascaded comb stages with an input data rate of $\frac{f_s}{R}$, followed by a rate change by a factor R , followed by N cascaded integrator stages with an output data rate of f_s . The differential delay, M , affects the slope of the transition region. Figure 1 diagrams the interpolating CIC filter.

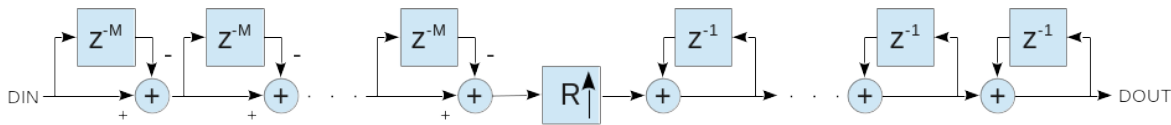

Figure 1: Cascaded Integration Comb Decimation filter Block Diagram

Worker Implementation Details

cic_int.hdl

Number of Stages

The generic N sets the number of integrators and comb stages in the filter. Increasing the number of stages increases the attenuation in the sidelobes and decreases the 3dB bandwidth of the passband. The recommended range for this parameter is 3 to 6. Consult the reference material for an in depth discussion of the frequency response of the filter as a function of the generics in this module.

Bit Growth

For this design, the output data width for the comb stages is configurable via `ACC_WIDTH`. To adjust for bit growth in the data path and to ensure no quantization error at the output, this equation should be used to determine the value of `ACC_WIDTH`.

$$ACC_WIDTH = N * CEIL(\log_2(R * M)) + DIN_WIDTH \quad (1)$$

Theory

A CIC filter is comprised of N integrator sections cascaded together with N comb sections. Combining the transfer functions for all sections results in the system response function seen in Equation 2. Note that the filter has zeros at integer multiples of $\frac{f_s}{RM}$ Hz.

$$H(z) = [H_{int}(z)]^N [H_{comb}(z)]^N = \left[\frac{1}{(1-z^{-1})^N} \right] [(1-z^{-RM})^N] = \frac{(1-z^{-RM})^N}{(1-z^{-1})^N} \quad (2)$$

Block Diagrams

Top level

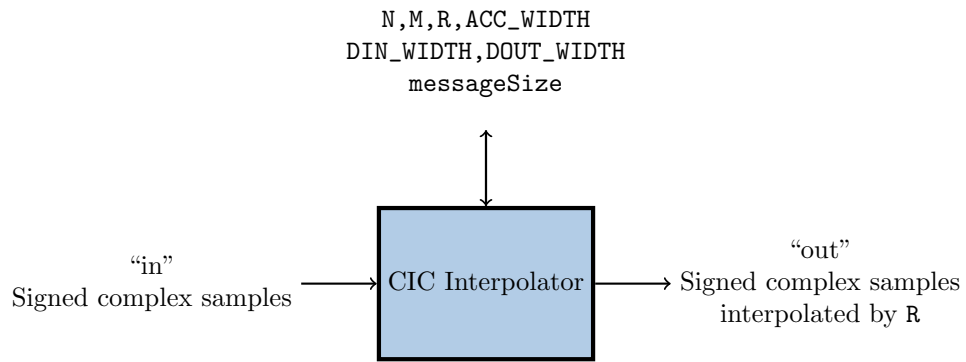

Figure 2: Top Level Block Diagram

Source Dependencies

cic_int.hdl

- assets/components/dsp_comps/cic_int.hdl/cic_int.vhd
- assets/hdl/primitives/dsp_prims/dsp_prims_pkg.vhd
assets/hdl/primitives/dsp_prims/cic/src/cic_int_gen.vhd

Component Spec Properties

Name	Type	SequenceLength	ArrayDimensions	Accessibility	Valid Range	Default	Usage
N	UChar	-	-	Readable	-	-	Number of Stages
M	UChar	-	-	Readable	-	-	Differential Delay
R	UShort	-	-	Readable	-	-	Interpolation Factor
ACC_WIDTH	UChar	-	-	Readable	-	-	Accumulation Width *(2)
DIN_WIDTH	UChar	-	-	Readable	-	-	Input data width
DOUT_WIDTH	UChar	-	-	Readable	-	-	Output data width
messageSize	UShort	-	-	Readable, Writable	-	8192	Number of bytes in output message

Worker Properties

cic_int.hdl

Type	Name	Type	SequenceLength	ArrayDimensions	Accessibility	Valid Range	Default	Usage
SpecProperty	N	-	-	-	Parameter	3-6	3	Number of Stages
SpecProperty	M	-	-	-	Parameter	1-2	1	Differential Delay
SpecProperty	R	-	-	-	Parameter	4-8192	4	Decimation Factor
SpecProperty	DIN_WIDTH	-	-	-	Parameter	16	16	Input Data Width
SpecProperty	ACC_WIDTH	-	-	-	Parameter	*	22	Accumulation Width *(2)
SpecProperty	DOUT_WIDTH	-	-	-	Parameter	16	16	Output Data Width
Property	CHIPSCOPE_p	Bool	-	-	Readable, Parameter	Standard	false	Include ISE ChipScope circuit
Property	VIVADO_ILA_p	Bool	-	-	Readable, Parameter	Standard	false	Include Vivado Integrated Logic Analyzer circuit

Component Ports

Name	Producer	Protocol	Optional	Advanced	Usage
in	False	iqstream_protocol	False	-	Complex signed samples (Q0.15 I, Q0.15 Q).
out	False	iqstream_protocol	False	-	Complex signed samples (Q0.15 I, Q0.15 Q).

Worker Interfaces

cic_int.hdl

Type	Name	DataWidth	Advanced	Usage
StreamInterface	in	32	ZeroLengthMessages=true	Signed complex samples
StreamInterface	out	32	ZeroLengthMessages=true	Signed complex samples

Control Timing and Signals

The CIC Interpolation filter HDL worker uses the clock from the Control Plane and standard Control Plane signals. This worker has a latency of $N*2+1$ valid input data clock cycles.

Latency
$N*2+1$

Worker Configuration Parameters

cic_int.hdl

Table 1: Table of Worker Configurations for worker: cic_int

Configuration	DOUT_WIDTH	ocpi_debug	M	R	VIVADO_ILA_p	CHIPSCOPE_p	ACC_WIDTH	ocpi_endian	N	DIN_WIDTH
0	16	false	1	4	false	false	22	little	3	16
1	16	false	2	4	false	false	25	little	3	16
2	16	false	1	5	false	false	23	little	3	16
3	16	false	2	5	false	false	26	little	3	16
4	16	false	1	8	false	false	25	little	3	16
5	16	false	1	16	false	false	28	little	3	16
6	16	false	1	2048	false	false	49	little	3	16
7	16	false	2	2048	false	false	52	little	3	16
8	16	false	1	2048	N/A	false	60	little	4	16
9	16	false	1	8191	N/A	false	55	little	3	16
10	16	false	2	8191	N/A	false	58	little	3	16
11	16	false	1	8192	N/A	false	55	little	3	16
12	16	false	2	8192	N/A	false	58	little	3	16

Performance and Resource Utilization

cic_int.hdl

Table 2: Resource Utilization Table for worker "cic_int"

Configuration	OCPI Target	Tool	Version	Device	Registers (Typ)	LUTs (Typ)	Fmax (MHz) (Typ)	Memory/Special Functions
0	stratix4	Quartus	17.1.0	EP4SGX230KF40C2	681	472	N/A	N/A
0	zynq	Vivado	2017.1	xc7z020clg484-1	678	548	N/A	N/A
0	zynq_ise	ISE	14.7	7z020clg484-1	639	611	252.016	N/A
0	virtex6	ISE	14.7	6vlx240tff1156-1	639	612	224.227	N/A
1	stratix4	Quartus	17.1.0	EP4SGX230KF40C2	833	496	N/A	N/A
1	zynq	Vivado	2017.1	xc7z020clg484-1	830	578	N/A	N/A
1	zynq_ise	ISE	14.7	7z020clg484-1	759	629	252.016	N/A
1	virtex6	ISE	14.7	6vlx240tff1156-1	759	630	224.569	N/A
2	stratix4	Quartus	17.1.0	EP4SGX230KF40C2	694	483	N/A	N/A
2	zynq	Vivado	2017.1	xc7z020clg484-1	691	557	N/A	N/A
2	zynq_ise	ISE	14.7	7z020clg484-1	645	625	251.361	N/A
2	virtex6	ISE	14.7	6vlx240tff1156-1	645	626	238.607	N/A
3	stratix4	Quartus	17.1.0	EP4SGX230KF40C2	848	507	N/A	N/A
3	zynq	Vivado	2017.1	xc7z020clg484-1	845	588	N/A	N/A
3	zynq_ise	ISE	14.7	7z020clg484-1	765	643	251.112	N/A
3	virtex6	ISE	14.7	6vlx240tff1156-1	765	644	238.607	N/A
4	stratix4	Quartus	17.1.0	EP4SGX230KF40C2	718	499	N/A	N/A
4	zynq	Vivado	2017.1	xc7z020clg484-1	715	580	N/A	N/A
4	zynq_ise	ISE	14.7	7z020clg484-1	659	636	252.321	N/A
4	virtex6	ISE	14.7	6vlx240tff1156-1	659	637	238.607	N/A
5	stratix4	Quartus	17.1.0	EP4SGX230KF40C2	755	524	N/A	N/A
5	zynq	Vivado	2017.1	xc7z020clg484-1	752	610	N/A	N/A
5	zynq_ise	ISE	14.7	7z020clg484-1	679	659	252.016	N/A
5	virtex6	ISE	14.7	6vlx240tff1156-1	679	660	238.265	N/A
6	stratix4	Quartus	17.1.0	EP4SGX230KF40C2	1014	722	N/A	N/A
6	zynq	Vivado	2017.1	xc7z020clg484-1	1011	837	N/A	N/A
6	zynq_ise	ISE	14.7	7z020clg484-1	819	856	245.415	N/A
6	virtex6	ISE	14.7	6vlx240tff1156-1	819	857	231.015	N/A
7	stratix4	Quartus	17.1.0	EP4SGX230KF40C2	1220	746	N/A	N/A
7	zynq	Vivado	2017.1	xc7z020clg484-1	1217	867	N/A	N/A
7	zynq_ise	ISE	14.7	7z020clg484-1	939	874	243.817	N/A
7	virtex6	ISE	14.7	6vlx240tff1156-1	939	875	229.598	N/A
8	stratix4	Quartus	17.1.0	EP4SGX230KF40C2	1507	1042	N/A	N/A
8	zynq	Vivado	2017.1	xc7z020clg484-1	1504	1193	N/A	N/A
8	zynq_ise	ISE	14.7	7z020clg484-1	1084	1083	244.378	N/A
8	virtex6	ISE	14.7	6vlx240tff1156-1	1084	1084	230.468	N/A
9	stratix4	Quartus	17.1.0	EP4SGX230KF40C2	1088	777	N/A	N/A
9	zynq	Vivado	2017.1	xc7z020clg484-1	1085	906	N/A	N/A
9	zynq_ise	ISE	14.7	7z020clg484-1	859	924	252.016	N/A

9	virtex6	ISE	14.7	6vlx240tff1156-1	859	927	238.607	N/A
10	stratix4	Quartus	17.1.0	EP4SGX230KF40C2	1306	801	N/A	N/A
10	zynq	Vivado	2017.1	xc7z020clg484-1	1303	936	N/A	N/A
10	zynq_ise	ISE	14.7	7z020clg484-1	979	942	252.016	N/A
10	virtex6	ISE	14.7	6vlx240tff1156-1	979	945	237.511	N/A
11	stratix4	Quartus	17.1.0	EP4SGX230KF40C2	1088	776	N/A	N/A
11	zynq	Vivado	2017.1	xc7z020clg484-1	1085	902	N/A	N/A
11	zynq_ise	ISE	14.7	7z020clg484-1	859	898	253.026	N/A
11	virtex6	ISE	14.7	6vlx240tff1156-1	859	901	238.607	N/A
12	stratix4	Quartus	17.1.0	EP4SGX230KF40C2	1306	800	N/A	N/A
12	zynq	Vivado	2017.1	xc7z020clg484-1	1303	932	N/A	N/A
12	zynq_ise	ISE	14.7	7z020clg484-1	979	916	252.016	N/A
12	virtex6	ISE	14.7	6vlx240tff1156-1	979	919	237.511	N/A

Test and Verification

Two test cases are implemented to validate the CIC Interpolator component:

1. Unity gain response to DC: The CIC Interpolator gain is calculated using the following equation:

$$CIC\ Gain = \frac{(R * M)^N}{2^{CEIL(N * \log_2(R * M))}} \quad (3)$$

2. Tone waveform: A waveform containing a tone at 50 Hz is sampled at 1024000/R and processed by the worker. The output data (interpolated waveform) is checked to ensure the 50 Hz tone is present.

For the plots below, a CIC Interpolator with the following parameter set was used: N=3, M=1, R=2048, and ACC_WIDTH=49.

For Case #1, the plots below show the input with the I-leg zoomed in the show the amplitude is 32767, and output data with the I-leg zoomed to show an amplitude of 32767, which can be calculated using 3, shown below, and the Q-leg showing the worker delay before reaching it steady-state value.

$$Output\ Amplitude = 32767 * \frac{(2048 * 1)^3}{2^{CEIL(3 * \log_2(2038 * 1))}} = 32767 * 1 = 32767 \tag{4}$$

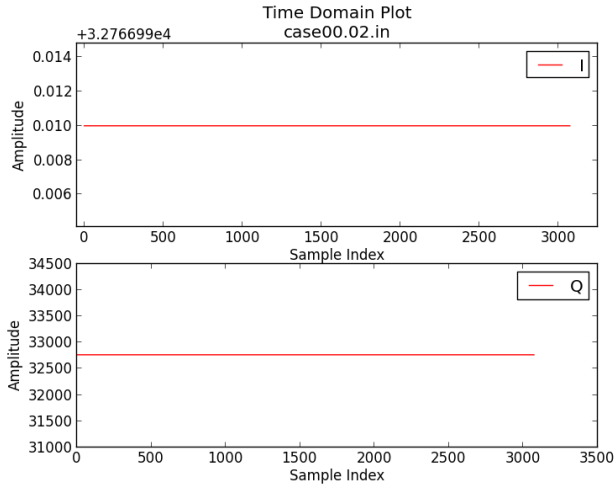

Figure 3: Time Domain: DC with amp=32767

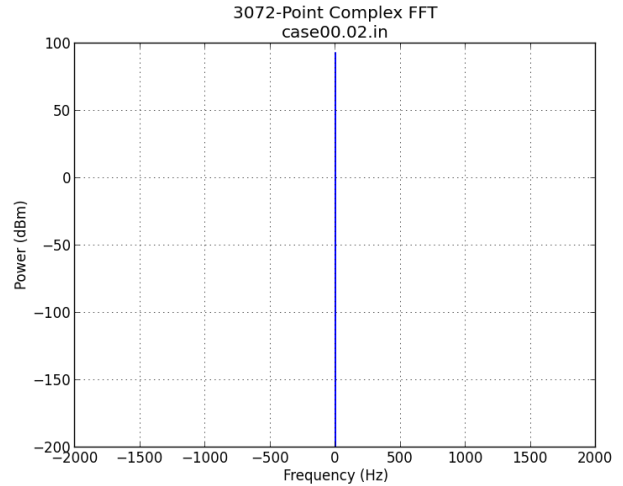

Figure 4: Frequency Domain: 0 Hz

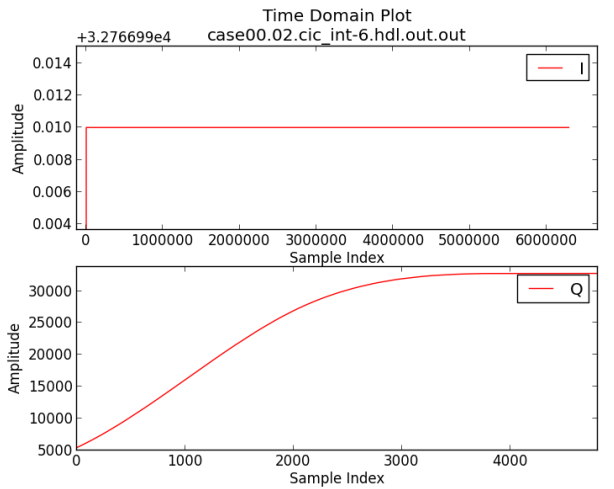

Figure 5: Time Domain: DC with amp=32767

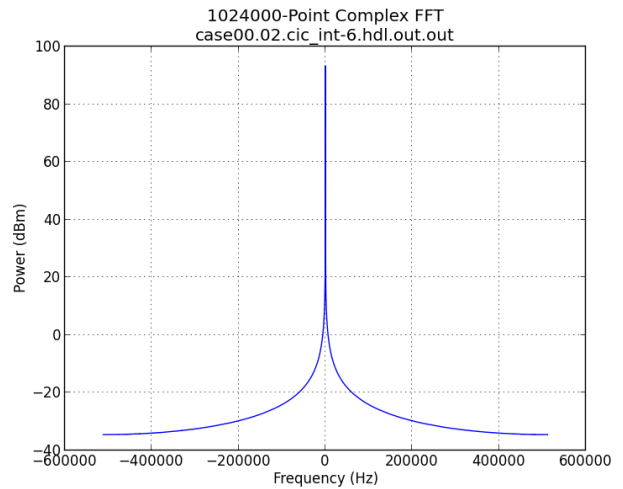

Figure 6: Frequency Domain: 0 Hz

The input time-domain plot below shows the I-leg zoomed into one cycle and Q-leg showing all samples of a 50 Hz tone sampled at $1024000/R=1024000/2048=500$ Hz, which results in 10 samples/cycle. The input freq-domain plot shows the generated tone at 50 Hz. The output time-domain plot below shows the I-leg zoomed into approximately two cycles and Q-leg showing all samples of a 50 Hz tone sampled at $(1024000/R)*R=(1024000/2048)*2048=1024000$ Hz, which results in 20480 samples/cycle. The output freq-domain plot shows the expected tone at 50 Hz.

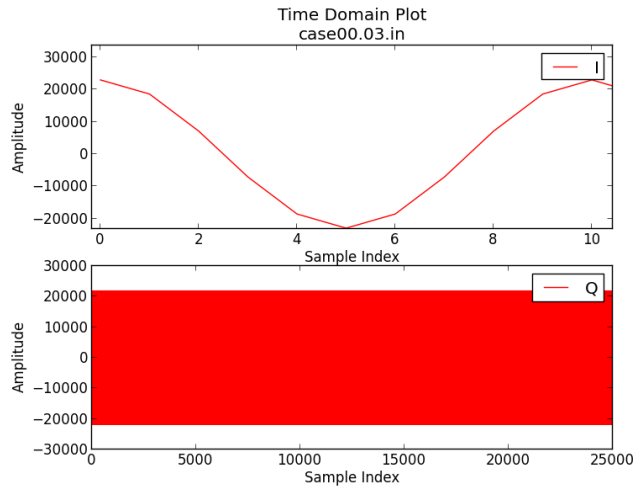

Figure 7: Time Domain

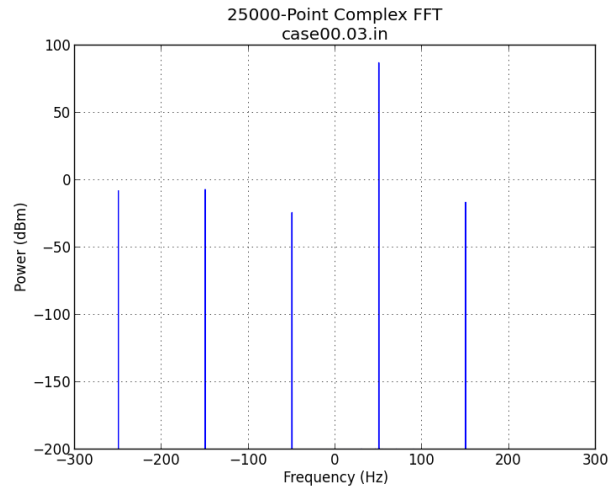

Figure 8: Frequency Domain: 50 Hz

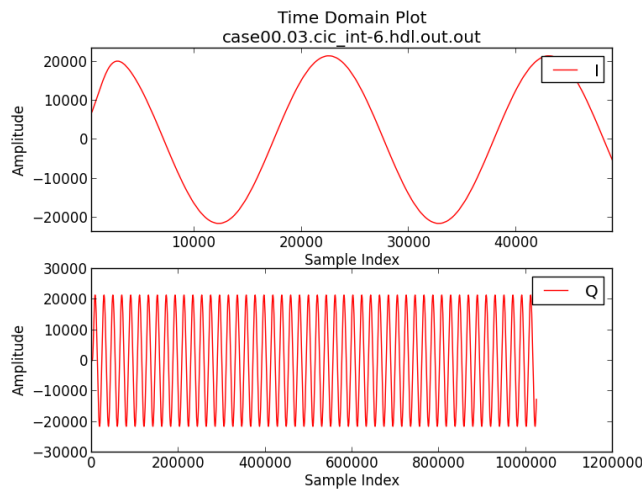

Figure 9: Time Domain

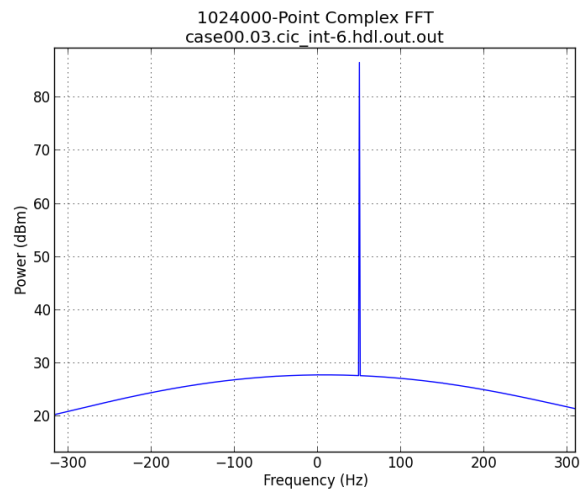

Figure 10: Frequency Domain: 50 Hz

References

- (1) Ronald E. Crochiere and Lawrence R. Rabiner. Multirate Digital Signal Processing. Prentice-Hall Signal Processing Series. Prentice Hall, Englewood Cliffs, 1983.
- (2) Eugene B. Hogenauer, An Economical Class of Digital Filters for Decimation and Interpolation, IEEE Transactions on Acoustics, Speech, and Signal Processing, Vol. ASSP-29, No. 2, April 1981.
- (3) Matthew P. Donadio, CIC Filter Introduction, <http://home.mit.bme.hu/~kollar/papers/cic.pdf>